

Typoszereg dla materiału DU

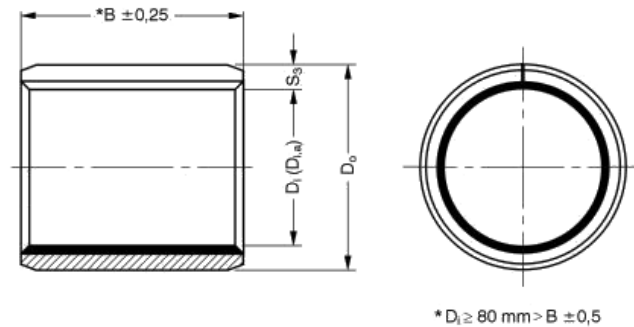

Tab. 1. Tuleje cylindryczne

Oznaczenie	Di	Do	B	Oznaczenie	Di	Do	B	Oznaczenie	Di	Do	B	Oznaczenie	Di	Do	B
0203DU	2	3,5	3	1512DU	15	17	12	3230DU	32	36	30	8040DU	80	85	40
0205DU	2	3,5	5	1515DU	15	17	15	3240DU	32	36	40	8060DU	80	85	60
0303DU	3	4,5	3	1520DU	15	17	20	3520DU	35	39	20	8080DU	80	85	80
0305DU	3	4,5	5	1525DU	15	17	25	3530DU	35	39	30	80100DU	80	85	100
0306DU	3	4,5	6	1610DU	16	18	10	3535DU	35	39	35	8530DU	85	90	30
0403DU	4	5,5	3	1612DU	16	18	12	3540DU	35	39	40	8560DU	85	90	60
0404DU	4	5,5	4	1615DU	16	18	15	3550DU	35	39	50	85100DU	85	90	100
0406DU	4	5,5	6	1620DU	16	18	20	3720DU	37	41	20	9060DU	90	95	60
0410DU	4	5,5	10	1625DU	16	18	25	4020DU	40	44	20	90100DU	90	95	100
0505DU	5	7	5	1720DU	17	19	20	4030DU	40	44	30	9560DU	95	100	60
0508DU	5	7	8	1810DU	18	20	10	4040DU	40	44	40	95100DU	95	100	100
0510DU	5	7	10	1815DU	18	20	15	4050DU	40	44	50	10050DU	100	105	50
0604DU	6	8	4	1820DU	18	20	20	4520DU	45	50	20	10060DU	100	105	60
0606DU	6	8	6	1825DU	18	20	25	4530DU	45	50	30	100115DU	100	105	115
0608DU	6	8	8	2010DU	20	23	10	4540DU	45	50	40	10560DU	105	110	60
0610DU	6	8	10	2015DU	20	23	15	4545DU	45	50	45	105115DU	105	110	115
0705DU	7	9	5	2020DU	20	23	20	4550DU	45	50	50	11060DU	110	115	60
0710DU	7	9	10	2025DU	20	23	25	5020DU	50	55	20	110115DU	110	115	115
0806DU	8	10	6	2030DU	20	23	30	5030DU	50	55	30	11550DU	115	120	50
0808DU	8	10	8	2215DU	22	25	15	5040DU	50	55	40	11570DU	115	120	70
0810DU	8	10	10	2220DU	22	25	20	5050DU	50	55	50	12050DU	120	125	50
0812DU	8	10	12	2225DU	22	25	25	5060DU	50	55	60	12060DU	120	125	60
1006DU	10	12	6	2230DU	22	25	30	5520DU	55	60	20	120100DU	120	125	100
1008DU	10	12	8	2415DU	24	27	15	5525DU	55	60	25	125100DU	125	130	100
1010DU	10	12	10	2420DU	24	27	20	5530DU	55	60	30	13060DU	130	135	60
1012DU	10	12	12	2425DU	24	27	25	5540DU	55	60	40	130100DU	130	135	100
1015DU	10	12	15	2430DU	24	27	30	5550DU	55	60	50	13560DU	135	140	60
1020DU	10	12	20	2515DU	25	28	15	5555DU	55	60	55	13580DU	135	140	80
1208DU	12	14	8	2520DU	25	28	20	5560DU	55	60	60	14060DU	140	145	60
1210DU	12	14	10	2525DU	25	28	25	6020DU	60	65	20	140100DU	140	145	100
1212DU	12	14	12	2530DU	25	28	30	6030DU	60	65	30	15060DU	150	155	60
1215DU	12	14	15	2550DU	25	28	50	6040DU	60	65	40	15080DU	150	155	80
1220DU	12	14	20	2815DU	28	32	15	6050DU	60	65	50	150100DU	150	155	100
1225DU	12	14	25	2820DU	28	32	20	6060DU	60	65	60	16080DU	160	165	80
1310DU	13	15	10	2825DU	28	32	25	6070DU	60	65	70	160100DU	160	165	100
1320DU	13	15	20	2830DU	28	32	30	6530DU	65	70	30	180100DU	180	185	100
1405DU	14	16	5	3010DU	30	34	10	6550DU	65	70	50	200100DU	200	205	100
1410DU	14	16	10	3015DU	30	34	15	6570DU	65	70	70	210100DU	210	215	100
1412DU	14	16	12	3020DU	30	34	20	7040DU	70	75	40	220100DU	220	225	100
1415DU	14	16	15	3025DU	30	34	25	7050DU	70	75	50	250100DU	250	255	100
1420DU	14	16	20	3030DU	30	34	30	7070DU	70	75	70	300100DU	300	305	100
1425DU	14	16	25	3040DU	30	34	40	7560DU	75	80	60				
1510DU	15	17	10	3220DU	32	36	20	7580DU	75	80	80				

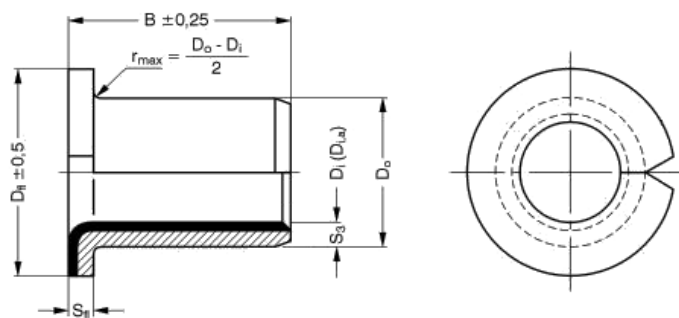

Tab. 2. Tuleje kołnierowe

Oznaczenie	Di	Do	B	Dfl	Oznaczenie	Di	Do	B	Dfl	Oznaczenie	Di	Do	B	Dfl
BB0304DU	3	4,5	4	7	BB1212DU	12	14	12	20	BB2022DU	20	23	21,5	30
BB0404DU	4	5,5	4	9	BB1217DU	12	14	17	20	BB2512DU	25	28	11,5	35
BB0505DU	5	7	5	10	BB1412DU	14	16	12	22	BB2517DU	25	28	16,5	35
BB0604DU	6	8	4	12	BB1417DU	14	16	17	22	BB2522DU	25	28	21,5	35
BB0608DU	6	8	8	12	BB1509DU	15	17	9	23	BB3016DU	30	34	16	42
BB0806DU	8	10	5,5	15	BB1512DU	15	17	12	23	BB3026DU	30	34	26	42
BB0808DU	8	10	7,5	15	BB1517DU	15	17	17	23	BB3516DU	35	39	16	47
BB0810DU	8	10	9,5	15	BB1612DU	16	18	12	24	BB3526DU	35	39	26	47
BB1007DU	10	12	7	18	BB1617DU	16	18	17	24	BB4016DU	40	44	16	53
BB1009DU	10	12	9	18	BB1812DU	18	20	12	26	BB4026DU	40	44	26	53
BB1012DU	10	12	12	18	BB1817DU	18	20	17	26	BB4516DU	45	50	16	58
BB1017DU	10	12	17	18	BB1822DU	18	20	22	26	BB4526DU	45	50	26	58
BB1207DU	12	14	7	20	BB2012DU	20	23	11,5	30					
BB1209DU	12	14	9	20	BB2017DU	20	23	16,5	30					

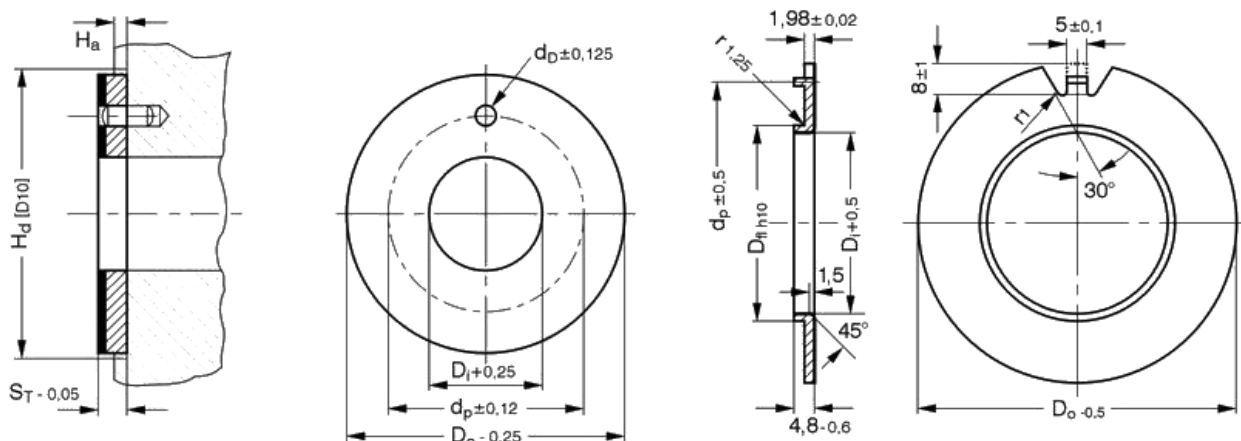

Tab. 3. Podkładki oporowe i kołnierowe

Oznaczenie	Di	Do	ST	dD	Dp	Ha	Oznaczenie	Di	Dfl	Do	dp
WC08DU	10	20	1,5			0,95-1,2	BS40DU	40,45	75	44	64,75
WC10DU	12	24	1,5	1,75	18	0,95-1,2	BS50DU	51,25	85	55	74,75
WC12DU	14	26	1,5	2,25	20	0,95-1,2	BS60DU	61,25	95	65	84,75
WC14DU	16	30	1,5	2,25	22	0,95-1,2	BS70DU	71,25	110	75	99,75
WC16DU	18	32	1,5	2,25	25	0,95-1,2	BS80DU	81,25	120	85	109,75
WC18DU	20	36	1,5	3,25	28	0,95-1,2	BS90DU	91,25	130	95	119,75
WC20DU	22	38	1,5	3,25	30	0,95-1,2	BS100DU	101,25	140	105	129,75
WC22DU	24	42	1,5	3,25	33	0,95-1,2					
WC24DU	26	44	1,5	3,25	35	0,95-1,2					
WC25DU	28	48	1,5	4,25	38	0,95-1,2					
WC30DU	32	54	1,5	4,25	43	0,95-1,2					
WC35DU	38	62	1,5	4,25	50	0,95-1,2					
WC40DU	42	66	1,5	4,25	54	0,95-1,2					
WC45DU	48	74	2	4,25	61	1,45-1,7					
WC50DU	52	78	2	4,25	65	1,45-1,7					
WC60DU	62	90	2	4,25	76	1,45-1,7					

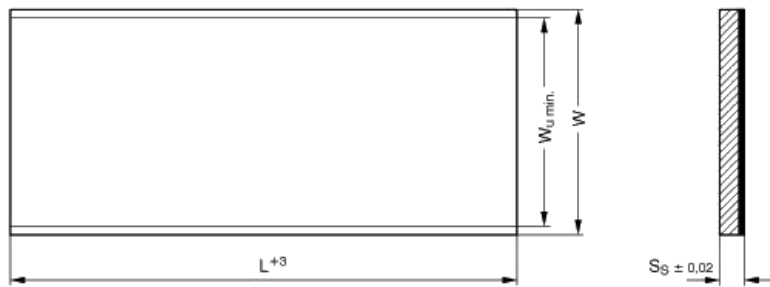

Tab. 4. Płyty

Oznaczenie	L	W	W _u	S _s
S07190DU	500	200	190	0,72
S10190DU	500	200	190	0,99
S15240DU	500	254	190	1,5
S20240DU	500	254	240	1,98
S25240DU	500	254	240	2,48
S30240DU	500	254	240	3,04